

Product Data

Section 9 Resilient Flooring Conductive & Static Dissipative Solid Vinyl Tile

1. PRODUCT NAME

Conductive & Static Dissipative Solid Vinyl Tile

2. COMPANY INFORMATION

Flexco Corporation

1401 East 6th Street

Tuscumbia, AL, USA 35674

Telephone: (256) 383-7474; (800) 633-3151

Facsimile: (256) 381-0322; (800) 346-9075

Email: info@flexcofloors.com, technical@flexcofloors.com

Internet: www.flexcofloors.com

Sweet's Catalog: 09650/FLE; Buyline 0254; www.sweets.com

3. PRODUCT DESCRIPTION

3.1 Basic Application

Flexco Conductive and Static Dissipative Solid Vinyl Tile effectively dissipates static electricity in hospital operating rooms, anesthetizing areas, radiological facilities, clean rooms, computer/data processing rooms, chemical laboratories, electronics manufacturing, telecommunications installations, pharmaceutical manufacturing, access flooring, ammunitions facilities and other areas where explosive elements are used and static electricity presents a hazard. Flexco Conductive and Static Dissipative Vinyl Tile helps control static charges on the human body, which can be as high as several thousand volts. By installing the tile with Flexco's specially formulated conductive adhesive, a continuous conductive pathway is created for static charges to flow through the tile and along the conductive adhesive to the ground point. The conductive flooring system attacks voltage generation at the source, the floor-shoe or floor-caster interface. When used in conjunction with static control footwear, the Flexco Conductive Static Control System provides greater mobility in the area. The use of wrist straps is recommended at the workstation for additional ESD control. It is ideal in areas requiring a solution for unwanted Human Body Voltage (HBV) with a high level of personnel traffic. Flexco Conductive and Static Dissipative Solid Vinyl Tile has a lifetime warranty to meet the industry standards for electrical resistance and keeps body voltage generation at the minimum levels demanded in the most sensitive environments. Flexco Conductive Vinyl Tile is UL listed.

3.2 Product Construction

Flexco Conductive and Static Dissipative Solid Vinyl Tile is a solid, homogeneous vinyl tile manufactured using first quality, virgin raw materials. Special ingredients are added to provide its excellent light stability, chemical resistance and to ensure an aesthetically pleasing finish without the need for waxing. This monolithic tile is uniform with respect to color, pattern effect, and composition, throughout the thickness of the tile. The unique chip pattern is appealing and requires no floor finish. Flexco Conductive and Static Dissipative Solid Vinyl Tile contain antimicrobials, which it makes it ideal for areas that require resistance to staining by fungi and streptovercillium reticulum, a pink stain organism. The pure virgin vinyl composition provides excellent resistance to abrasion, chipping, cracking and permanent indentations for heavy-duty performance requirements. It helps conceal most substrate irregularities, and yet it is flexible for fast and economical installations. Flexco Conductive and Static Dissipative Solid Vinyl Tile may be "heat welded" producing a seamless, Unitized Installation. To complement the variety of styles, coordinating wall base and accessories are available. Flexco's new high technology cutting system ensures a Precision Squared™ tile for a precision fit.

3.3 Product Types

Conductive and Static Dissipative Vinyl Tile

- Gauge: 1/8" (3.175 mm)
- Sizes: 12" x 12" (304.8 mm x 304.8 mm), 24" x 24" (609.6 mm x 609.6 mm) and 36" x 36" (914.4 mm x 914.4 mm), All noted sizes are nominal and Fractional Sizes are available for use on raised/access flooring panels
- Pre-grooved (Beveled) Edges available in 24" x 24" (609.6 mm x 609.6 mm) and 36" x 36" (914.4 mm x 914.4 mm) for Heat Welded Unitized Tile Installation System
- Available Colors; Fourteen standard colors available, see website www.flexcofloors.com for the latest color selection
- Custom Color Tile Matching is available
- Floorcraft Custom Designs are available; Computer-controlled, precision cutting service available for logos, signage or other images incorporated into the flooring layout.

3.4 Vinyl Welding Rods for Conductive and Static Dissipative Vinyl Tile

- Vinyl Welding Rods Dimensions; Vinyl Welding Rods are 0.160" (4 mm) in diameter and packaged in 400 linear foot rolls
- Vinyl Welding Rods Ordering Calculations;
 - 24" x 24" Tiles; The total square feet of tile divided by 400 equals the number of rolls of vinyl welding rods required
 - 36" x 36" Tiles; The total square feet of tile divided by 600 equals the number of rolls of vinyl welding rods required
- Available Colors; Matching Vinyl Welding Rods for all standard tile colors are available
- Custom Color Vinyl Welding Rod is available

4. TECHNICAL DATA

ASTM F 1700 - Specification for Solid Vinyl Tile; Class I, Type A; Federal Specification SS-T-312B, Type III

ASTM F 150 - Electrical Resistance;

- Conductive, 2.5×10^4 to 1×10^6
- Static Dissipative, 1×10^6 to 1×10^8
- UL779 (UL Listed No. 22L9), ANSI/ESD S7.1-2005, NFPA 99

Federal Standard Test Method 101C, Method 4046(101c) - Static Decay; Conductive and Static Dissipative Passes, 5000 volts to 0 volts is < 0.01 second

AATCC 134 - Static Propensity; Passes

- Conductive is < 5 volts with conductive shoes
- Static Dissipative is < 20 with conductive shoes

ASTM E 648 (NFPA 253) - Critical Radiant Flux; Class 1, > 1.00 W/cm²

ASTM E 662 (NFPA 258) - Specific Optical Density of Smoke Generated by Solid Materials; Passes, < 450

ASTM E 84 (NFPA 255) - Surface Burning Characteristics, Flamespread;

- Standard formula, Class B (26 – 75)
- Class A formula, Class A (0 – 25)

UL 992 - Surface Flame Propagation; Passes, < 2.0

ASTM F 925 - Resistance to Chemicals; Passes, List of chemicals available

ASTM D 570 - Water Absorption of Plastics; < 0.15%

ASTM D 2047 - Static Coefficient of Friction (Slip Resistance); > 0.50, < 0.70; dry, flat surface using neolite sensors

ASTM F 970 - Static Load Limit; 250 PSI; Modified ASTM F 970, 2000 PSI

ASTM F 1515 - Light Stability; Passes

ASTM E 595 - Outgassing; Excellent, Test results available

FED-STD-209E - Airborne Particulate Cleanliness; Excellent, Test results available

EN 425 - Castor Chair Test; Passes

ASTM F 510 - Abrasion Resistance; Excellent

FMVSS 302, Title 49, Part 571 - Flammability of Interior Materials; Passes

ASTM G 21 - Determining Resistance of Synthetic Polymeric Materials to Fungi; Excellent Resistance

ASTM E 1428 - Performance of Antimicrobials in or on Polymeric Solids against Staining by Streptovorticillium Reticulum (A Pink Stain Organism); 0, No stain

AATCC Test Method 147 - Antibacterial Activity Assessment of Textile Materials-Parallel Streak; NZ, No Zone

5. PRODUCT LIMITATIONS

Flexco Conductive and Static Dissipative Solid Vinyl Tile must be installed using Flexco 66/67 Solvent Free ESD Epoxy Adhesive and in accordance with Flexco recommendations in order for the product warranty to be in effect.

Caution: The use of some types of paper/fabric footwear covers (booties) or similar footwear covers used in hospital or clean-room applications may inhibit the slip resistance properties of the flooring. The proper ESD footwear such as heal grounders or ESD shoes must be worn to assure proper performance. It is recommended that ESD wrist straps be worn at work stations in conjunction with foot grounders. Flexco does not recommend the use of floor finishes, sealers or waxes of any kind, as they may form an insulating layer on the tile surface and adversely affect the performance of the product. When using Static Dissipative floor finishes, the electrical properties may be affected and therefore testing results and or performance is the sole responsibility of the floor finisher and/or facility owner. If an ESD floor finish is required, contact Flexco Technical Service for recommendations prior to applying any floor finishes. Flexco Conductive and Static Dissipative Solid Vinyl Tile may have manufacturing sheen or shade variances until initial maintenance is performed. Flexco Conductive and Static Dissipative Solid vinyl tile may be stained if it is allowed to remain in contact with products that may contain staining ingredients such as tires, casters, and walk-off mats. Ensure that any disinfectant, cleaning agent, dye, pesticide, or other chemical (solid, liquid, or gas) that may come in contact with the flooring will not produce permanent discoloration and/or damage to the flooring. If any of the chemicals are not on the stain resistance chart, the tile must be tested prior to installation. Contact Flexco Customer Service for a stain resistance chart and for assistance in conducting stain testing. Flexco Conductive and Static Dissipative Vinyl Tile is not to be used in or near commercial kitchens or other areas exposed to animal fats, greases, oils, solvents, strong detergents or where there is excessive moisture. Flexco Conductive and Static Dissipative Vinyl Tile must not be used in areas that may be subjected to sharp spikes, cleats, sharp wheels, or other objects that could damage the flooring. Use appropriate floor protection devices. Dragging or improperly moving furniture or equipment across the surface of the tile or dropping objects onto the surface of the tile may cause permanent damage to the flooring. The flooring is not to come in contact with direct heat, such as radiators, hot ovens or other heated equipment. This product is for indoor use only with temperatures maintained from 65° F (19° C) and 85° F (30° C). Flexco Conductive and Static Dissipative Solid Vinyl Tile is a specialty product and should be installed in areas for control of ESD only. Color selections must be made from actual samples as exact matching of color, shade, and/or mottling may vary. Read all of the product information on installation, maintenance and product limitations/precautions before beginning the installation. The Flexco recommended installation instructions, maintenance instructions and product limitations/precautions must be adhered to in order for the product warranty to be valid. Follow all local, state, and federal safety standards and practices.

6. INSTALLTION

6.1 General Preparation and Conditioning

Read the literature concerning the product description, product limitations, product installation, adhesive information, product maintenance and warranty before installing the tile. All materials including recommended adhesive are to be delivered to the installation location in its original packaging with labels intact. **DO NOT** stack pallets of material as this will cause damage. Store products in a dry area protected from the weather on a smooth, flat, dry surface with temperatures maintained between 65° F (19° C) and 85° F (30° C). Remove all plastic wrapping and strapping from the pallets upon arrival to the installation area and at least 48 hours prior to installation. For proper acclimation, remove the tile from the cartons and stack evenly on a smooth dry surface with each stack no more than 18" high. When stacking tiles prior to and during installation, place the tiles face-to-face and sanded back-to-sanded back to prevent the sanded back of the tiles from being contaminated and to protect the product from damage. The installation area, tile, adhesive and welding rods are to be maintained between 65° F (19° C) and 85° F (30° C) for a minimum of 48 hours prior to installation. These temperature ranges must be maintained throughout the installation phase and thereafter. If temperatures other than Flexco's requirements become an issue, contact the Flexco Technical Service Department prior to installation. **Notice:** Tile should be loose laid in the room or area prior to spreading of adhesive to determine the proper layout to ensure the best overall appearance and to minimize small border cuts. Inspect all material for proper type and color. Conduct the proper moisture emission and pH testing on the substrate. Proceed with the installation only when the conditions are proper and correct. A bond test using Flexco 66/67 Solvent Free ESD Epoxy

Adhesive throughout the area approximately 50 feet apart should be performed at least one week prior to the scheduled installation to ensure the surface is suitable. After 72 hours, there should be an unusual amount of force to lift tile from the substrate with adhesive bonding to the tile and the substrate. **Caution:** Close the area to traffic during flooring installation and 48 hours after installation. Install tiles and accessories after other finishing operations, including painting, have been completed. If the back of the tile becomes soiled prior to installation, clean with a clean soft cloth dampened with clean water or denatured alcohol and allow to completely dry. Tile may be installed over radiant heated floors, provided the surface temperature is maintained between 65° F (19° C) and 85° F (30° C). If radiant-heated floors have cooled after installation, a gradual increase in temperature is required to prevent adhesive bond from being adversely affected. **Caution:** You will find an arrow on the back, sanded side of each tile. It is important that each tile be installed with the arrow in the same direction. If the tiles are not laid in the same direction, the reflection of light will cause an optical illusion, making the surface appear to be different shades. If the tiles are installed at random, disregarding the arrows on the back, it will require extensive buffing with 3M 5300 Blue Cleaner pads and occasionally 3M 7200 Brown Stripper Pads with a 175-300 RPM buffer. Follow all local, state, and federal standards and practices for the proper removal and disposal of flooring, adhesives, or other materials. Follow all local, state, federal, and manufacturer's safety standards for the use of all products and equipment.

6.2 Subfloor/Substrate Inspection and Preparation

6.2.1 General

All subfloors/substrates must be inspected prior to installation. All substrates must be clean, smooth, permanently dry, flat, and structurally sound. The substrate must be free of moisture, dust, sealers, paint, curing compounds, parting agents, residual adhesives, adhesive removers, hardeners, resinous compounds, solvents, wax, oil, grease, asphalt, gypsum compounds, alkaline salts, excessive carbonation or laitance, mold, mildew, any other extraneous coatings, films, materials and all other foreign matter which might interfere/restrict proper adhesive bonding. **DO NOT** use sweeping compounds, solvents, citrus adhesive removers, or acid etching to clean the substrate. **DO NOT** install flooring over gypsum-based or plaster based leveling or patching compounds. **DO NOT** install new floor covering over old floor covering, as the old floor covering may not be adequately bonded, hide possible structural defects or cause plasticizer migration into the new flooring. In renovation or remodel work, remove all existing adhesive residue so that 100% of the overall area of the original subfloor/substrate is exposed (**Caution:** Some previous manufactured asphaltic "cutback" contained asbestos). Follow The Resilient Floor Covering Institute's (RFCI) "Recommended Work Practice for Removal of Existing Floor Covering and Adhesive", and all applicable industry, local, state, and federal standards. Care must be taken to analyze the conditions and correct any problems prior to installation. Follow the manufacturer's recommendations for any patching or underlayment materials, excluding gypsum based or plaster based levelers or patching compounds.

6.2.2 Concrete Substrates

Concrete substrates on all Grade Levels must be tested in accordance with ASTM F 1869 Standard Test Method for Measuring Moisture Vapor Emission Rate of Concrete Subfloor Using Anhydrous Calcium Chloride or ASTM F 2170 Standard Test Method for Determining Relative Humidity in Concrete Floor Slabs using *in situ* Probes to quantitatively determine the amount of moisture vapor emission at least one week prior to the installation. **Caution:** ASTM F 1869 or ASTM F 2170 tests cannot predict long-term moisture conditions of concrete slabs. Moisture testing only indicates moisture conditions at the time the tests are performed. Before conducting ASTM F 1869 or ASTM F 2170 test, the installation area must be maintained between for 65° F (19°C) and 85° F (30°C) or at least 48 hours prior to testing, during testing and thereafter. In addition, the concrete's temperature range must also be identical to that of the installation area. Conduct three tests for the first 1,000 sq. ft. and one additional test for each 1,000 sq. ft. or fraction thereof per grade level (on, below or above grade). The Vapor Emission Rate shall not exceed 5.0 lbs and Relative Humidity Test shall not exceed 75% when using Flexco 66/67 Solvent Free ESD Epoxy Adhesive. If the substrate does not meet the above noted requirements, the flooring shall not be installed until the problem has been corrected. **DO NOT** install flooring if there is hydrostatic pressure. Every concrete floor slab on-grade or below grade to receive resilient flooring shall have a permanent, effective moisture vapor retarder installed below the slab. A pH test must be performed to test for excessive alkalinity using a pH pencil or litmus paper and deionized water. A scaly, sandy, or powdery surface is an indication of some form of contaminant, usually excessive alkalis or an alkali-silica residue. A pH reading higher than 8 is an indication of a potential problem and the concrete must be neutralized by rinsing with clear water. Apply clear water with a mop and allow to thoroughly dry. Re-rinse with clear water, allow to thoroughly dry and retest to ensure pH level is within acceptable range of 5 to 8 on the pH scale. Continue to neutralize

until the pH level is acceptable. The testing of concrete for alkalinity indicates the degree of alkalinity only at the time the test is conducted, and cannot be used to predict long-term conditions. Moisture and alkali salts in the concrete can cause the following problems after installation: adhesive deterioration, bumps, ridges, bubbles, discoloration, mold, mildew, bacteria growth, efflorescence, tile shifting, tile releasing, tile peaking and/or sheet seam curling. **DO NOT** install over burnished (slick troweled) concrete to avoid adhesive and underlayment patch or self-leveling bonding problems due to the non-porosity of the concrete finish. Corrective measures such as bead blasting (shot blasting) or scarifying must be performed prior to installation. The concrete slab must be of good quality, standard density concrete with low water/cement ratios consistent with placing and finishing requirements, having a maximum slump of 4", a minimum compressive strength of 3500 PSI, and following the recommendations of ACI Standard 302.1R-96 for class 2 or call 4 floors and the Portland Cement Association's recommendations for slabs on ground. Joints such as expansion joints, contraction joints, isolation joints, saw cuts, control joints, grooves or other moving joints shall not be filled with patching compound or covered with resilient flooring. Expansion joint covers designed for use with resilient flooring should be used. Any non-moving surface cracks, depressions, and other irregularities shall be filled and smoothed with a high quality grade Portland cement-based, water resistant, non-shrinking, non-staining, mildew resistant, alkali resistant underlayment having a minimum compressive strength of 3500 PSI after 28 days. Some underlayments may fail under excessive weight; an epoxy caulking compound may be required for certain repairs. Mechanically cleaning the substrate by shot-blasting, scarifying and/or sanding shall be performed to achieve a flat, smooth, clean surface to prevent irregularities, roughness or other defects from telegraphing through the new resilient flooring. The surface of the concrete shall be flat to within the equivalent of 3/16" in 10 feet, as described in ACI 117R. The surface shall be cleaned of all loose material by scraping, brushing, vacuuming and/or other methods immediately before commencing installation of resilient flooring. Follow the proper safety practices during the preparation and installation. Follow the recommendations of the American Concrete Institute (ACI 302.1R, *Guide for Concrete Floor and Slab Construction*; ACI 360.R, *Design of Slabs on Grade*; ACI 223, *Standard Practice for the Use of Shrinkage-Compensating Concrete*); The American Society for Testing and Materials (ASTM F 710, *Standard Practice for Preparing Concrete Floors and Other Monolithic Floors to Receive Resilient Flooring*), and the American National Standards Institute (ANSI A157.1, *Recommended Practice for Concrete Floor and Slab Construction*) for the preparation of concrete to receive resilient flooring.

6.2.3 Wood Subfloors

Wood subfloors should be of double layer construction with a minimum thickness of 1". Crawl spaces underneath wood subfloors shall be in compliance with local building code ventilation practices and have clearance of at least 18" of cross-ventilated space between the ground level and joists. Wood joists should be spaced on not more than 16" centers. Place a moisture retarder; having a maximum rating of 1.0 perm, on the top of the ground under the wood subfloor overlapped at least 8". APA, The Engineered Wood Association, Underlayment Grade plywood, minimum 3/8" thick, with a fully sanded face is to be used. Use APA approved exterior grade plywood if finished floors are subjected to moisture. OSB, lauan, maranti, solid-core mahogany, waferboard, particleboard, chipboard, flakeboard, tempered hardboard, glass mesh mortar units or cementitious tile backer boards, sheathing-grade plywood, preservative-treated plywood and/or fire-retardant treated plywood are not recommended as some manufacturers may use resins or other adhesives in the manufacturing of the product that may cause discoloration or staining of the flooring. Wood subfloor movement, flexing or instability will cause the flooring installed to release, buckle or become distorted. Do not proceed with the installation until corrective measures have been made. The warranties, performance, installation and uses are the responsibility of the wood subfloor manufacturer and/or contractor. **DO NOT** use plastic or resin filler to patch cracks. **DO NOT** use cement or rosin coated nails/staples, or solvent-based construction adhesive to adhere the plywood. Installation on a sleeper, a wood subfloor system constructed over the top of concrete, is not recommended. Installation directly over Sturd-I-Floor panels is not recommended. All wood subfloors, single construction plywood floors, single and/or double tongue-and-groove strip floors, and wood plank floors must be prepared to receive resilient flooring in accordance with federal and industry standards. Follow the recommendations of the APA, The Engineered Wood Association, Design/Construction Guide, Residential and Commercial, and ASTM F 1482, Standard Guide to Wood Underlayment Products Available for Use under Resilient Flooring, for the installation and proper construction of the panels to receive resilient flooring. It is the contractor's responsibility to determine if the subfloor is acceptable to receive the flooring (Refer to 6.2.1).

6.2.4 Terrazzo and Ceramic Floors

Terrazzo and ceramic floors to be used as subfloors/substrates are to follow the procedures recommended for concrete in 6.2.2. Ceramic tile must be solidly adhered and all loose tiles must be removed and repaired or replaced. Ensure all glazed, sealed, smooth and/or shiny surfaces are properly sanded and cleaned. Fill all grout lines and other irregularities with a Portland cement-based underlayment with a minimum compressive strength of 3500 PSI. The subfloor must be structurally sound. Inspect and ensure there is an adequate bond of the old flooring to the original substrate. Flexco will not warranty the product if there is a bond failure caused by problems relating to the old flooring (Refer to 6.2.1).

6.2.5 Metal Floors

Metal floors to be used as subfloors/substrates must be thoroughly cleaned of any residue, oil, rust and/or oxidation and properly sanded/grinded to provide a smooth, level, clean substrate to receive the resilient flooring. The flooring must be installed within 12 hours after sanding/grinding to prevent the metal flooring from re-oxidizing. The metal subfloor shall be structurally sound. Deflection of the metal floor can cause a bond failure between the adhesive and the metal substrate. On an extremely smooth, non-porous, metal substrate, a longer “tack up” may be required in order to prevent the adhesive from oozing between the seams. **Caution:** The installation of stair-treads, risers or other flooring materials will not prevent deterioration of metal substrates from occurring.

6.3 Adhesive Information

6.3.1 Flexco 66/67 Solvent Free ESD Epoxy Adhesive

Flexco 66/67 Solvent Free ESD Epoxy Adhesive must be used for the installation of Flexco Conductive and Static Dissipative Solid Vinyl Tile. It is a solvent free, non-flammable, high performance epoxy adhesive for indoor installations over porous and non-porous substrates on grade, below grade or above grade. It is available in both quarts and gallon units. When used on non-porous substrates, the adhesive must be allowed to “tack up” before placing tiles. The approximate spread rate using the 1/32” deep x 1/16” open x 1/32” “U” notch trowel provided, is 175 square feet on smooth, steel troweled concrete or a non-porous substrate. Over porous or rough substrates, a 1/16” x 1/16” x 1/16” flat “V” notch trowel may be required; spread rate for this trowel is approximately 150 square feet. Coverage will vary according to the type of surface, surface texture, spreading angle and/or adhesive temperature. Although the epoxy components are non-freezing, the adhesive must be allowed to stabilize to ambient temperature before mixing. Shelf life is one year @ 70° F (21° C) from adhesive manufacturing date in an unopened container. Wet adhesive on the surface of the tiles or surrounding area must be removed immediately with a clean cloth dampened with warm soapy water or denatured alcohol. **DO NOT** allow adhesive to cure on the surface of the tile. **Caution:** A bond failure will occur if the epoxy is not properly mixed. Label information is in English and Spanish. Read all of the product and safety information concerning the adhesive and any other chemicals or cleaning agents prior to installation.

Flexco 66/67 Solvent Free ESD Epoxy Adhesive is Green Label Plus certified by the Carpet & Rug Institute. Part A VOC's 9 g/L, Part B VOC's 20 g/L; 14.3 g/L when mixed.

6.4 Adhesive Application and Product Installation

6.4.1 Adhesive Application

Flexco Conductive and Static Dissipative Vinyl Tile installation should only be performed with the Flexco 66/67 Solvent Free ESD Epoxy Adhesive. Read all installation literature before proceeding. Prior to adhesive application, dry lay the flooring to ensure desired aesthetics (refer to 6.1). Follow safety precautions on the adhesive label and Material Safety Data Sheet. Ensure the installation area has adequate ventilation. **DO NOT** mix partial units of this adhesive, because the ratio of Part A to Part B is not 1:1. Flexco 66/67 Solvent Free ESD Epoxy Adhesive is packaged in two separate containers marked Part A (epoxy resin) and Part B (polyamide resin, hardener). Remove the lids and add all of Part A into Part B. Mix the combined parts using a rotary motion while at the same time lifting from the bottom. A slow speed, 200 RPM maximum drill, with an attached mixing paddle may also be used. Mix for a minimum of 3 minutes with drill or 5 minutes by hand. After mixing, there must be no streaking of the two parts in the adhesive; it will be consistent black color. **Caution:** Higher mixing speeds and/or longer mixing time will reduce the open time and can cause premature curing of the adhesive; however, if not mixed long enough, the adhesive will not properly cure. **DO NOT** allow the mixed epoxy adhesive to stand in the container. Immediately after mixing, pour the contents onto the substrate. Immediately spread the adhesive evenly with the 1/32” deep x 1/16” open x 1/32” “U” notch trowel provided, while being careful to leave no puddles of adhesive. If the substrate has been shot blasted or a rough textured

underlayment has been applied, additional adhesive may have to be purchased to ensure proper adhesive coverage.

Note: Over extremely porous or rough concrete, a 1/16" x 1/16" x 1/16" flat "V" notch trowel may be required.

Caution: If too much adhesive is applied, oozing and telegraphing may occur along with adhesive displacement when the tile is rolled or subjected to rolling loads or lateral shear stress, resulting in loose areas and adhesive telegraphing. Spreading large areas of adhesive in excess of 175 square feet could possibly allow the adhesive to cure or setup before the tile is installed which would result in a bond failure. Allow the adhesive to "tack up" which takes approximately 15 minutes at 70° F (21° C) and 50% humidity. **Caution:** "Tack up" time, open time, and curing characteristics will vary upon the type of substrate, temperature of the substrate, ambient temperature, humidity, proper mixing of the adhesive and proper conditioning of the adhesive. Observe the adhesive to ensure the adhesive has not surpassed its open time and started to cure.

6.4.2 Product Installation

6.4.2.1 Tile Placement

You will find an arrow on the back, sanded side, of each tile. It is important that each tile be installed with the arrow in the same direction putting the rough sanded side with the arrow into the adhesive. If the tiles are not laid in the same direction, the reflection of light will cause an optical illusion, making the surface appear to be different shades. **Note:** If the tiles are installed at random, disregarding the arrows on the back, it will require extensive buffing with 3M 5300 Blue Buffer Pads using a 175-300 RPM buffer followed with Red and White pads for polishing. When laying the flooring use a kneeling board, or for best results, work off the flooring whenever possible to avoid shifting of the tile. Ensure the epoxy adhesive is not tracked onto the surface of the tile. If the adhesive is bleeding or oozing at the seams, either too much adhesive is being applied or the adhesive is too wet. Immediately remove the excessive wet adhesive with a clean cloth dampened with warm soapy water or denatured alcohol before the epoxy cures. After cleaning with denatured alcohol, rinse with a clean soft cloth dampened with clean water. **DO NOT** allow the epoxy to cure on the surface of the tile; it will be extremely difficult to remove. **Note:** If heat welding, the vinyl welding rods will not adhere to adhesive left remaining in the pre-grooved seam. Periodically, lift the tile to check for proper adhesive transfer. There should be at least a 90% transfer of adhesive on the back of the tile. Also observe the adhesive to ensure the adhesive has not surpassed its open time and started to cure. Borders and other specialty cut tiles must be scribed and cut fit snugly but not tightly, against the wall, threshold, transition strip, fixtures and/or other obstacles. **DO NOT** wait until all the main aisle flooring has been installed to begin laying the borders. Roll and cross roll each section of tile laid with a 100-pound, 3-section roller within 20 minutes after the tile section has been installed. Use a hand roller in areas that cannot be reached with the larger roller. Conduct a visual inspection during the rolling process to ensure there has been no shifting of the tiles and that there is no adhesive on the surface of the tile. **DO NOT** wait until the entire installation is completed before rolling as the adhesive may have surpassed its open time. Inspect each section laid after rolling to check for raised edges. Roll and cross roll a second time approximately 30 minutes after the initial rolling. If necessary, roll and cross roll again. There is to be no foot traffic on the floor for at least 48 hours and no wheeled conveyances for at least 3 days. Protect flooring against damage.

6.4.2.2 Grounding & Grounding Diagram

To ground the conductive flooring to a known ground, use the 1" wide x 0.004" thick x 18" long copper foil strips which are supplied by Flexco. Place approximately 9" of the strip into Flexco 66/67 Solvent Free ESD Epoxy Adhesive while the adhesive is still wet to ensure a 100% transfer to the copper foil backing, under the tile nearest the ground point. Flexco 66/67 ESD Adhesive must also be applied to the top section of the copper foil strips in order to complete the conductivity and to bond the tile to directly to the copper foil strips. Allow the other half, approximately 9", of the length of the strip to "pigtail" up the wall to permit an electrician to mechanically connect the copper foil to the ground point. If using a specifically supplied ESD facility grounding system, a ground bus bar would be placed near the floor where any ESD ground can be connected. If bus bars are not used, the ESD ground wire is normally #10 or #12 stranded copper wire supplied by the electrical contractor, is placed inside the wall from a ground bus and a hole is cut into the drywall for the wire to exit at the floor/wall junction where the copper foil has been placed. Grounding to the green wire ground in the wiring system may also be used; Refer to the Grounding Diagram that follows. Use longer copper foil strips if necessary. Place the copper strips approximately every 2000 square feet along the perimeter of the floor or where the ground points are located and/or at least one per room. The ground connection may also be made directly to an exposed steel support column. The connection must be mechanically secured to the column. The point of contact on the column must be clean and dry, and free of any paint or other substance that would prevent adequate metal contact. Protect or enclose all connections as required by safety codes. Make sure that all

expansion joints, saw-cuts and other necessary openings are bridged with a copper strip to ensure continuity. Resistance testing should be conducted in accordance to the test method, voltage, and conditions specified.

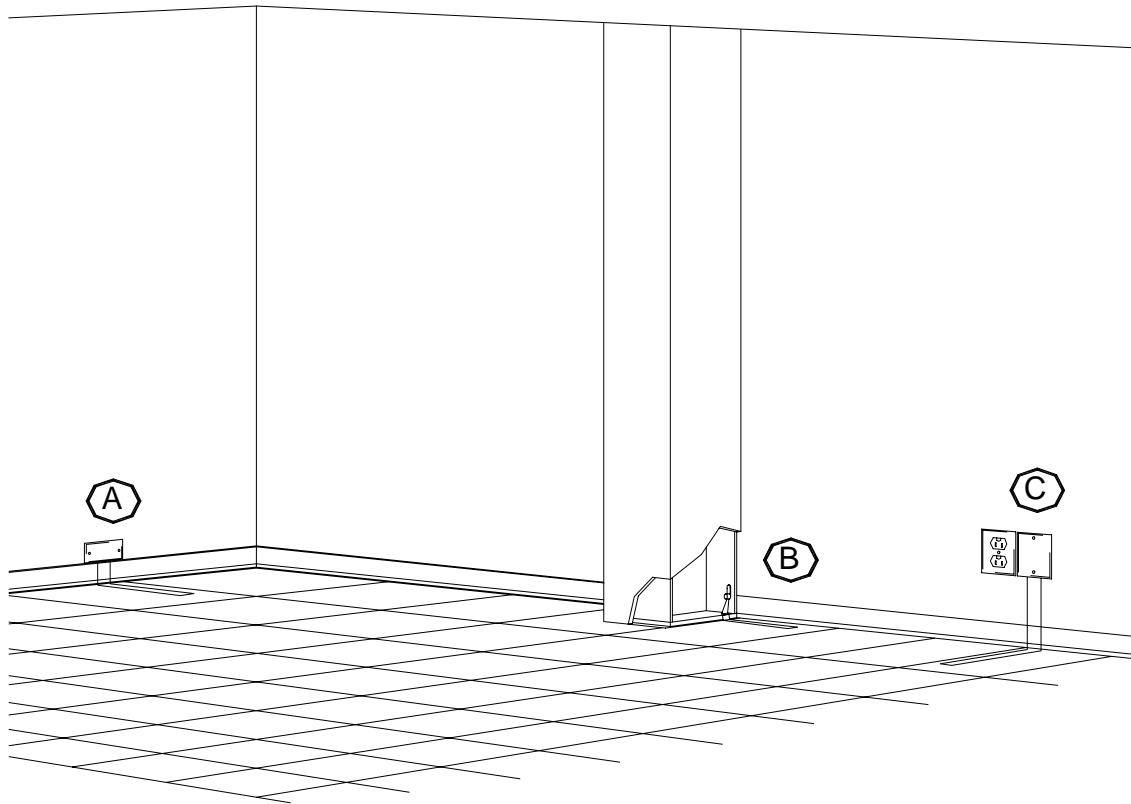

Common accepted ESD Tile system grounding methods

- A. Specific ESD grounding system built into the facility design.
- B. Building column: Steel columns or grounded building framing system provides an acceptable ground for ESD flooring. Grounding lug fastened to steel framing per NEC requirements
- C. Connect the copper strap to the green ground wire jumpered from a receptacle box.

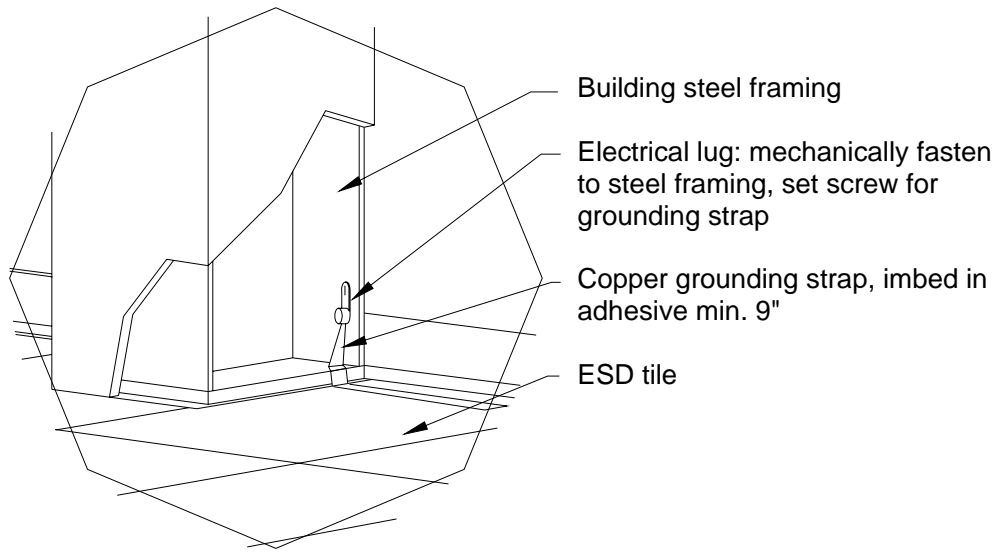

Note: Steel building frame must be properly grounded

Detail **B**

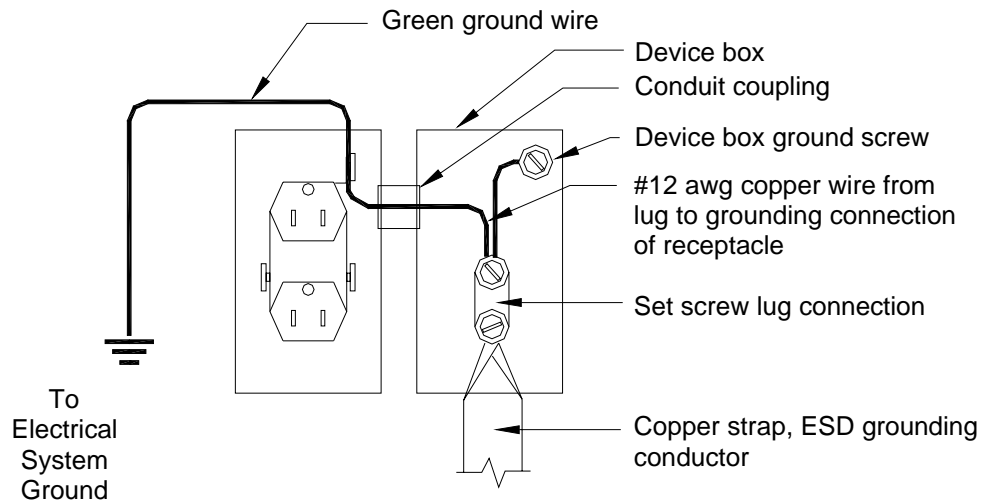

Detail **C**

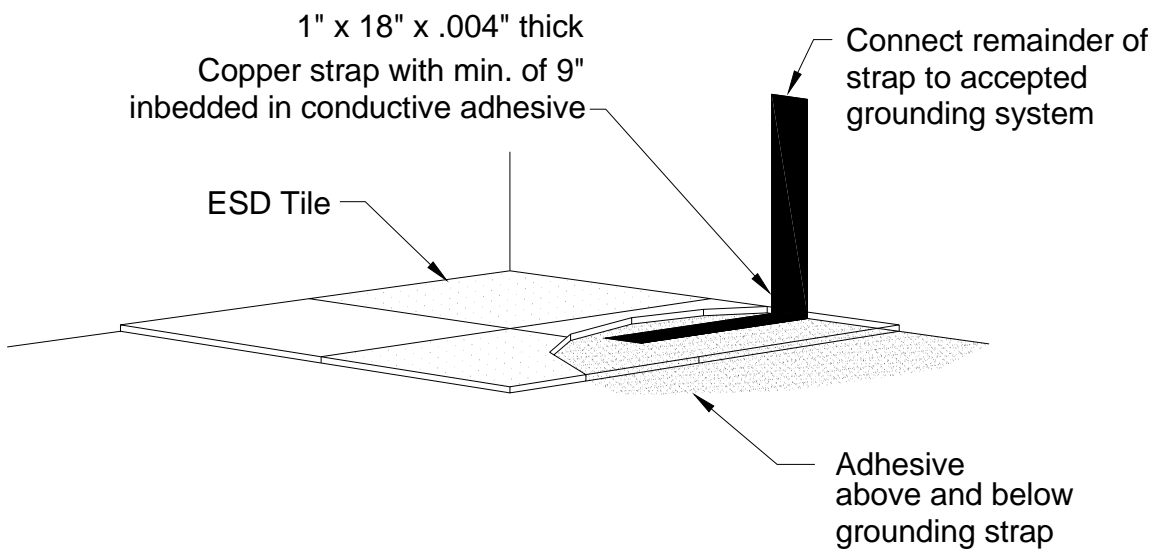

Strap installation detail

6.4.2.3 Flash Cove Procedure

Install field tile prior to flash cove. Allow a minimum of 6" flash up the wall and extending at least 6" on the floor. Install the desired Flexco Resilient Cove Cap at the desired height. Install metal inside and outside corners, making sure cove cap and corner height match. Corners can be formed on the job site. Install the Flexco #195 Cove Stick Filler at the wall and floor junction to provide the desired radius. Measure and cut in your flash cove. Using a heat gun, heat the tile uniformly over the entire length and bend to desired radius, making sure you have good contact with the cove stick. Use a piece of scrap to test bending procedure and **DO NOT** overheat tiles. To make both inside corners and outside butterfly corners, use building felt to create a dry pattern. Cut the tile to the pattern. Heat it, trim it and fit into place. For outside corners, after cutting and grooving your butterfly piece, heat it, and fit into place. Use a hand grooving tool on the butterfly piece and the rest of the corner at the point where they meet to prepare them for heat welding. As an alternative, preformed metal corners may be used. All flash cove sections should be pre-formed and allowed to cool prior to spreading adhesive. Final heating and forming should be made after adhesive has been applied. Use Flexco 16/86 Multi-Performance Tile and Tread Adhesive on the wall for installation of flashed-cove pieces of tile. Use Flexco 66/67 Solvent Free ESD Epoxy Adhesive on the floor and allow the adhesive to overflow on the cove strip. Weld the flash cove tile to the field tiles and up the wall. Trim flash cove seams using an X-ACTO knife with a blade to make it easy to trim inside and outside corners.

6.4.2.4 Unitized Heat Weld Procedure

Flexco Conductive and Static Dissipative Vinyl Tiles are available pre-grooved in 24" x 24" (609.6 mm x 609.6 mm) and 36" x 36" (914.4 mm x 914.4 mm) sizes; eliminating the need for routing on the job. It may be necessary to hand rout or use an electric grooving machine in some areas depending upon the job condition. **DO NOT** heat weld the seams until the adhesive has cured, approximately twenty-four (24) hours after the installation of the flooring. After installation and prior to heat welding, protect all seams from dirt, topical moisture and cleaning of any kind. **DO NOT** allow the adhesive to bleed at the seam. The Vinyl welding bead will not weld to the adhesive. If the installation is to be routed on the job, the preferable method is to use an electric grooving machine with the blade set to cut the groove approximately 66% of the total thickness of the tile (.082", if the flooring is 1/8" thick). During the grooving process, ensure approximately 50% of material is equally removed from each side of the adjoining pieces of the tile that is being grooved. Practice on a piece of scrap tile to obtain the proper depth. Temperature of the flooring and welding bead prior to and during installation must be between 65° F (19° C) and 85° F (30° C). It may be necessary to hand groove some of the seams using a hand grooving tool with a narrow blade near the walls or other obstacles. While grooving, pre-heat the welding gun as recommended by the manufacturer. After the grooving is completed use a hot air welding gun, insert the Flexco Vinyl Welding Bead through the opening of the 4mm welding tip into the center of the routed groove in the flooring. Practice the welding technique by using a piece of scrap tile to determine the temperature setting of the heat gun and welding speed to achieve a successful bond. Ensure the groove and welding bead are clean, dry and free of any contaminant that may prevent a successful bond when heat welded together. Follow the recommended welding procedures provided by the welding gun manufacturer. Begin welding at the wall and move toward the center. You can see the tile and bead flowing together while welding if the settings are correct. Welding too slowly may char or burn the tile. An excessive welding speed will not allow the bead and tile to reach the proper temperature for a successful bond. Ensure sufficient downward pressure is applied to fill the groove. Work with seams in one direction at a time, cut a "V" groove in installed bead at tile intersections, and then complete the procedure in opposite direction. **DO NOT** Allow traffic until rods have cooled and are trimmed. Allow the welding bead to completely cool and trim the excess bead with a clean, sharp quarter moon spatula knife with an attached clean, trim plate. After one hour, perform a second trim using only the quarter moon spatula knife to create a smooth, level surface. If the heat welded seam is trimmed before it is completely cold, and/or, if the seam is first cut with only the quarter moon spatula knife without trim the trim plate, a concave skive can result. This can allow particulate and liquids into the seam. After trimming, carefully glazing the surface of the heat welded seam with the hot air from the gun may smooth out any imperfections.

6.5 Testing for Electrical Resistance

Flexco recommends that the "ESD" (Conductive or Static Dissipative) flooring system be tested for electrical resistance approximately seven (7) days after the installation. The adhesive must be allowed to properly cure and the flooring system to stabilize to the ambient conditions. The electrical resistance will be tested according to ASTM F 150, ANSI/ESD S7.1-2005, NFPA 99, and UL 779. Test will be conducted at 10 volts for conductive tile. If readings are unacceptable, 100 volts should be used and that should be the default reading. Use 100 volts only for Static

Dissipative Tile. Perform both point to point and point to ground tests. Testing will also be conducted according to any special test method or procedure as specified by the customer in the specification.

7. PRODUCT MAINTENANCE

7.1 Initial Maintenance

7.1.1 Chemical/Liquid Cleaning

The tile must be properly cleaned before it is released for normal use. Do not scrub, buff or mop the tile for at least 48 hours after installation to allow the adhesive and heat welds to properly cure. Do not flood the tile when cleaning and do not allow the cleaning solution or topical moisture to work its way beneath the tile which can result in an adhesive and/or tile failure. Remove any covering that may have been used to protect the floor. First, Sweep and vacuum to remove dirt and other particulates, then damp mop the flooring with a neutral pH cleaner such as Spartan Chemicals' Green Solutions All Purpose Cleaner, TASKI Profi, Johnson's Stride, or Butchers Hot Springs or similar neutral pH cleaners. Follow the manufacturer's recommendations for a medium soil level cleaning. **DO NOT** use highly alkaline or acidic cleaners. **DO NOT** use sweeping or cleaning agents containing oils or solvents. Rinse the flooring immediately after mopping with clean warm water and remove rinse water with a wet/dry vacuum and allow to thoroughly dry before exposing to traffic. To remove excessive dirt, scuffs, or light scratches, after the installation; wet buff using a low speed rotary buffer, 175-300 RPM with a 3M 5300 Blue Cleaner Pad. Follow with a dry buff using a 3M 5100 Red Buffer Pad and a dry buff using a 3M 4100 White Super Polish Pad to achieve the required glossy appearance. Higher luster or sheen can be achieved by using more RPM when polishing with the White pad. Always check for compatibility and performance prior to cleaning by utilizing uninstalled material or test in an inconspicuous area before proceeding to determine if the desired results can be achieved without distorting, scratching or having an adverse effect on the tile. **DO NOT** heel the buffing machine. **DO NOT** flood the floor. **Caution:** When wet, the flooring will become slippery; therefore, use the appropriate warning signs on the floor to eliminate foot or vehicular traffic.

7.1.2 Dry Buffing

DO NOT dry buff until floor has been wet cleaned. Sweep, dust mop, or vacuum the floor to remove dirt and other particulate before dry buffing. Dry buff with a low speed rotary buffer, 175-300 RPM using a 3M 4100 White Super Polish Pad to achieve the desired glossy appearance. If directional sheen or light shading is present, dry buff with a 3M 5300 Blue Cleaner Pad followed with a 3M 5100 Red Buffer Pad, then the 3M 4100 White Super Polish Pad. Always check for compatibility and performance prior to cleaning by utilizing uninstalled material or test in an inconspicuous area before proceeding to determine if the desired results can be achieved without distorting, scratching or having an adverse effect on the tile. **DO NOT** heel the buffing machine.

7.2 Routine Maintenance

7.2.1 General Information

Insufficient cleaning will reduce the wear life of the flooring & reduce or eliminate the ESD properties. Therefore, the floor must be properly maintained. The amount of maintenance required is directly related to the amount and type of traffic and type of particulate deposited on the floor. There are several alternative maintenance systems available by contacting: TASKI Professional Building Care (800-862-3600), Spartan Chemicals (800-537-8990), Johnson Professional Wax (800-558-2332), or The Butcher Company (888-291-7510). The floor care product manufacturers will assist you in determining the best maintenance program. **Caution:** Some germicides, disinfectants, cleaning agents, floor maintenance products, and pesticides may stain or damage the surface of solid vinyl tile; therefore, test the products to ensure they will not stain or damage the tile. Periodic cleaning with a 3M 5300 Blue Cleaner Pad may be required to prevent buildup of germicidal cleaners or other cleaning solutions which may form an insulating barrier that can affect the conductivity of the floor. **Caution:** Dirt and other particulate allowed to remain on the flooring will reduce the wear life and will increase the electrical resistance of the flooring. Spills of any type must be removed immediately to help prevent staining or permanent damage. Contact Flexco Customer Service to obtain information concerning stain resistance to various chemicals and products. **DO NOT** use sweeping or cleaning agents containing oils or solvents. **DO NOT** use kerosene, gasoline, naphtha or other solvents on vinyl flooring. Reserve all mops, brushes, buckets, steel wool discs, and other materials for the EXCLUSIVE use of the maintenance of Flexco Conductive and Static Dissipative Vinyl Tile. If maintenance equipment and materials are used in other areas, they may become contaminated with waxes, oils or other contaminants that could hinder the performance of the flooring. Floor finishes and waxes are not recommended as they may leave an insulating film on the floor. If the decision is

made to use a floor finish, Flexco does not warranty the performance of the floor finish, sealers or waxes of any kind, nor will be held liable if the conductivity or dissipative properties of the flooring is either reduced or eliminated. When using floor finishes, sealers or waxes, the electrical properties may be affected and therefore testing results and or performance is the sole responsibility of the floor finisher and/or facility owner.

7.2.2 Routine Chemical/Liquid Cleaning

Sweep, dust mop or vacuum the flooring to remove dirt and other particulate. Damp mop or scrub with a commercial low speed scrubber, 175-300 RPM, using a neutral pH cleaner such as Spartan Chemicals' Green Solutions All Purpose Cleaner, TASKI Profi, Johnson Stride, Butchers Hot Springs or similar neutral pH cleaners to clean the flooring. For normal wet cleaning use a 3M 5100 Red Buffer Pad for scrubbing. To remove excessive dirt, scuffs, or light scratches, wet buff using a 3M 5300 Blue Cleaner Pad. Follow the manufacturer's recommendations for light or general cleaning. Allow the cleaning solution to stand for approximately 10 to 15 minutes; however **DO NOT** allow the solution to dry. Wet vacuum or mop up the residue. Rinse with clean, cool water, remove the water, and allow the flooring to thoroughly dry. **DO NOT** flood the floor.

7.2.3 Routine Dry Buffing

After wet cleaning, dry buffing can be performed on a routine basis to maintain the surface luster. Sweep, dust mop or vacuum the floor to remove dirt and other particulate before dry buffing. Dry buff with a low speed rotary buffer, 175-300 RPM; using a 3M 5100 Red Buffer Pad followed with a 3M 4100 White Super Polish Pad to achieve the desired glossy appearance. **DO NOT** heel the buffing machine. Use the wet cleaning procedure described in "Wet Cleaning" to remove the build up and for restorative maintenance.

8. TECHNICAL SERVICES

8.1 Technical Assistance

Obtain Technical Service information and assistance by calling Flexco Customer Service or by visiting www.flexcofloors.com

8.2 Samples

Obtain samples by calling Flexco Customer Service or by visiting www.flexcofloors.com

9. AVAILABILITY AND COST

Products are available through Flexco distributors. Contact Flexco Customer Service or visit www.flexcofloors.com for a list of distributors

10. LIMITED WARRANTY

Flexco Corporation manufactures and markets its floor products under the trade name Flexco®. Flexco Conductive and Static Dissipative Vinyl Tiles are warranted for a period of one (1) year from date of installation to be free of defects in material and workmanship, ten (10) year Limited Wear Warranty and Lifetime Conductivity; if installed, used under normal wear and traffic as designed and maintained in accordance with Flexco's written instructions. Flexco Conductive and Static Dissipative Solid Vinyl Tile Product Data information concerning Product Limitations, Installation and Maintenance may be obtained from a Flexco distributor or by writing Flexco, Attention: Customer Service Manager, 1401 E. 6th Street, Tuscumbia, Alabama, 35674. Notice of any defect must be made in writing to Flexco within thirty (30) days after buyer learns of the defect. Flexco does not warranty the performance of the floor finishes, sealers, waxes of any kind, nor will be held liable if the conductivity or dissipated properties of the flooring is either reduced or eliminated, or if the flooring is adversely affected in any way. No merchandise is to be returned prior to Flexco's inspection and written approval. Buyer's sole and exclusive remedy against Flexco and Dealer for claims arising hereunder for any and all losses and damages resulting from any cause shall be a pro rated credit, based on the period remaining in this Limited Warranty, toward the purchase of new Flexco Conductive and Static Dissipative Solid Vinyl Tile. Replacement credit shall be equal to the proportion of Limited Warranty time remaining multiplied by the current price of Flexco Conductive and Static Dissipative Vinyl Tile. In no event shall Flexco be liable for incidental or consequential damages, even if some other provision of this Limited Warranty is unenforceable. Flexco will not be liable for labor costs or lost profits resulting from the use of or inability to use the product. Buyer waives all other claims and remedies of any nature. Flexco Conductive and Static Dissipative Vinyl Tiles are not designed for use in or near commercial kitchens or for outdoor use. Flexco shall have no liability whatsoever to Buyer in the event the goods

become defective, if such defect is caused in whole or part by cuts, tears, vandalism, fire, willful destruction, damage from high heels, spiked footwear, improper installation, improper maintenance, subfloor and/or substrate irregularities, accidents, natural causes and/or acts of God. These warranties are expressly in lieu of any other warranties expressed or implied, including, but not limited to any implied warranty of merchantability or fitness for a particular purpose. By retaining Flexco's merchandise for more than five (5) days after receipt of such merchandise, Buyer agrees that it accepts the terms of this Limited Warranty and that there are no warranties or rights beyond those contained herein. All claims must be made in writing and sent to Flexco in the appropriate manner. All claims for surface defects or variations in color or pattern must be delivered to Flexco in writing before the product is installed. Flexco will not accept the return of any product without prior written approval of the Flexco Technical Department.

